

J. MAY.
Gage Lathe.

Patented April 2, 1878.

No. 201,932.

Fig. 1.

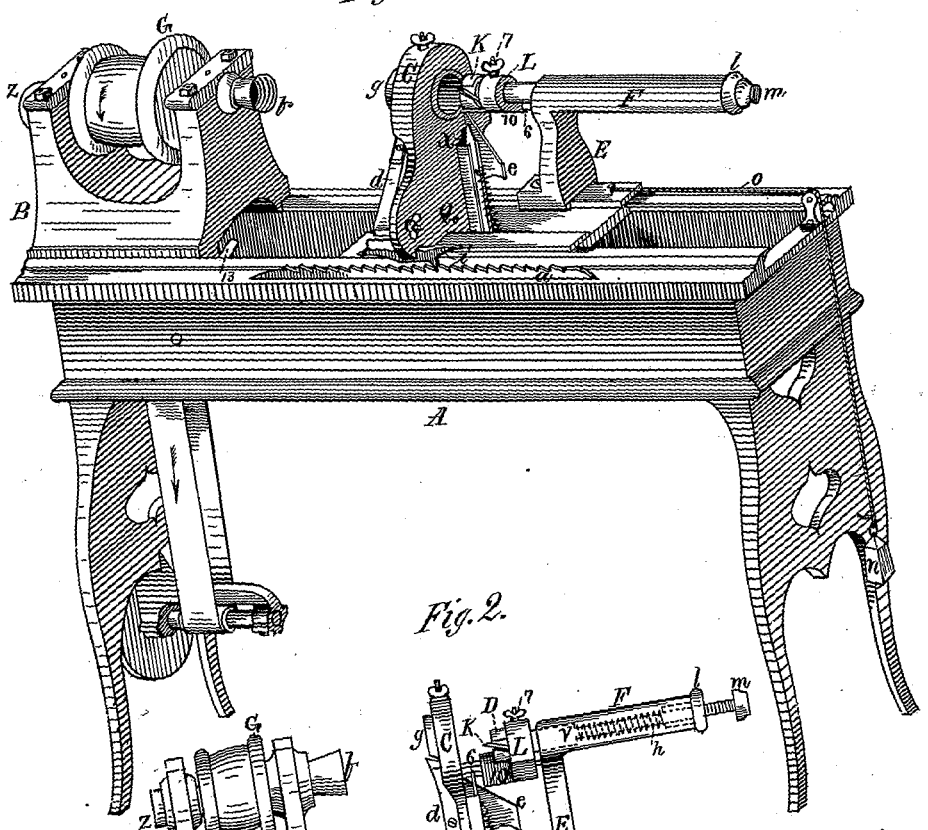
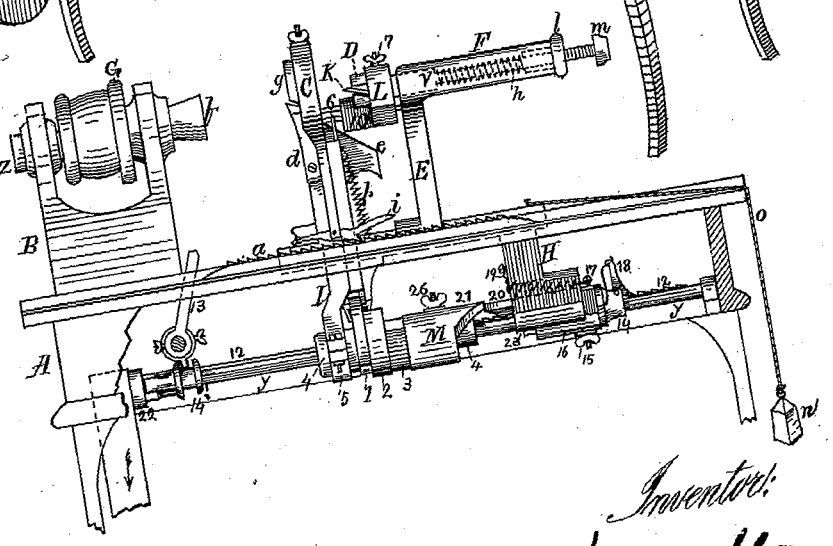

Fig. 2.



Witnesses:
H. E. Metcalf
Clarence Hendrick

Inventor:
James May
 Per *C. C. Shaw*
 Atty.

J. MAY.
Gage Lathe.

No. 201,932.

Patented April 2, 1878.

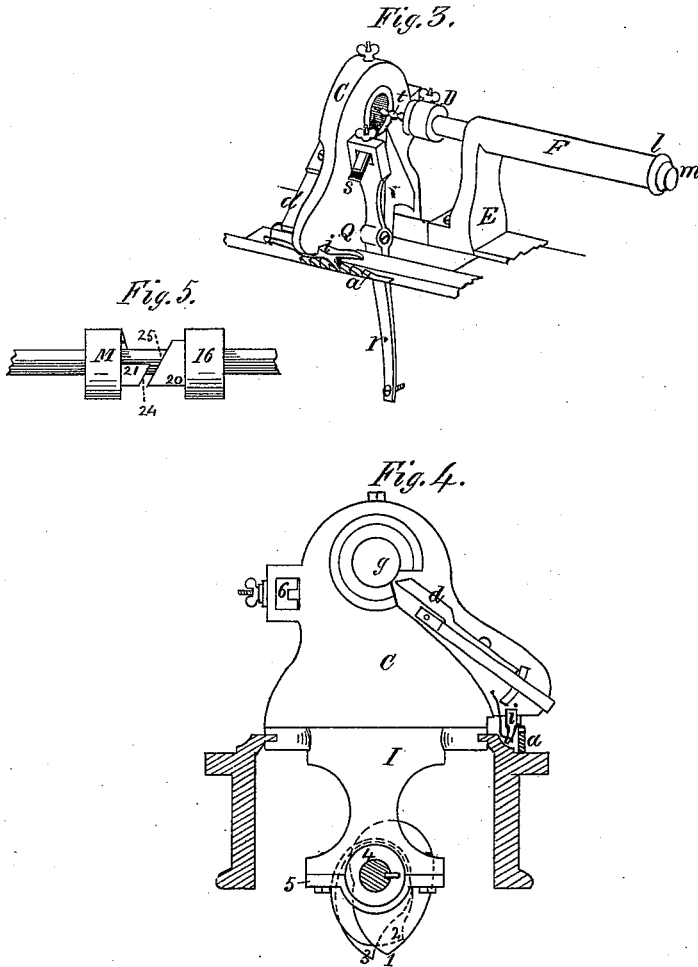

Witnesses:
H. E. Metcalf
Clarence Hendrick.

Inventor:
James May,
Per C. Shaw,
Att'y.

UNITED STATES PATENT OFFICE.

JAMES MAY, OF CAMBRIDGE, MASSACHUSETTS.

IMPROVEMENT IN GAGE-LATHES.

Specification forming part of Letters Patent No. **201,932**, dated April 2, 1878; application filed December 23, 1877.

To all whom it may concern:

Be it known that I, JAMES MAY, of Cambridge, county of Middlesex, and State of Massachusetts, have invented certain new and useful Improvements in Turning-Lathes, of which the following is a description sufficiently full, clear, and exact to enable any person skilled in the art or science to which my invention appertains to make and use the same, reference being had to the accompanying drawings, forming a part of this specification, in which—

Figure 1 is an isometrical projection; Fig. 2, a sectional side elevation, showing the feeding mechanism; Fig. 3, a view of the carriage, showing the spool-knife and bit attached; Fig. 4, a transverse sectional view, showing the vertical cams and the inner face of the carriage; and Fig. 5, a sectional view of the horizontal cams.

Like letters and figures of reference indicate corresponding parts in the different figures of the drawing.

My invention relates to that class of lathes which are provided with automatic feeds, and designed more especially for the manufacture of wooden boxes, spools, &c., and consists in a novel construction and arrangement of the parts, as hereinafter more fully described and claimed, by which a simpler, cheaper, and more effective device of this character is produced than is now in ordinary use.

The nature and operation of my improvements will be readily understood by all conversant with such matters from the following description.

In the drawing, A represents the body, B the head-stock, and C the carriage, of the lathe. A driving or speed pulley, G, is horizontally journaled on the shaft or mandrel *z* in the head-stock, the inner end of the mandrel being provided with the usual converging screw-socket or chuck *b*.

Projecting upwardly from the carriage C there is a bracket or standard, E, having a horizontal arm, F. This arm is hollow, and provided with a cap, *l*, through which passes the adjusting-screw *m*. A boring knife or bit is mounted in the cutter-head D, which has a shank extending into the arm F, and is provided with a coiled spring, *h*, one end of which

abuts against the inner end of the screw *m*, and the other against a shoulder, *v*, on the shank. A collet, L, is secured to the shank of the cutter-head by means of the set-screw 7, and is provided with a laterally-projecting arm, 10, having a horizontally-arranged spline, (not shown,) which works in a groove (not shown) in the bar 6. This bar is firmly secured horizontally in the standard E and carriage C, and operates, in conjunction with the arm 10, collet L, and screw 7, to prevent the cutter-head from turning or revolving, but not from sliding longitudinally in the arm F.

Projecting downwardly from the carriage C, between the sheers or runways of the lathe, are two arms, H I, connecting the carriage with the shaft *y*, which forms a part of the feed mechanism. This shaft is journaled horizontally beneath the bed of the lathe in parallelism with the mandrel *z*, as best seen in Fig. 2, and is provided with a sliding clutch, 14', and clutch-lever 13, to couple it with the pulley 22. Two sleeves, 4 and 14, are also disposed on the shaft, being so constructed and arranged as to slide longitudinally thereon, but prevented from revolving independently of the shaft by the fixed serrated spline 12, which works in grooves (not shown) on the interior of the sleeves. The sleeve 14 is provided at its outer end with a spring-pawl, 18, and carries an auxiliary sleeve, 16, having vertically-flattened sides. The lower end of the arm H is bifurcated and elongated, as seen at 23', being fitted loosely astride of the flattened sleeve 16 in such a manner that the forks of the arm prevent the sleeve from rotating, but not from moving longitudinally.

The sleeve 14 is provided with an annular groove (not shown) on its exterior surface, into which the inner end of the dog or screw 15 in the sleeve 16 projects, thus leaving the sleeve 14 free to revolve within the sleeve 16, but coupling them together in such a manner that their longitudinal movements necessarily correspond.

The sleeve 4 is exteriorly grooved near its outer end, and into this groove the lower end of the arm I is fitted, and kept in place by the strap or cap 5, forming a box, in which the sleeve can rotate, but not move longitudinally.

Disposed on the sleeve 4 are a series of ver-

tically-arranged face-cams, 1 2 3, and the supplemental sleeve or thimble M, which last is secured thereto by the set-screw 26. The sleeve M is provided with a horizontal cam, 21, having one of its sides straight and one inclined, the sleeve 16 being provided with a corresponding cam, 20, one of its sides being also straight and one inclined, as best seen in Fig. 5.

A vertically-reciprocating bar, *e*, having an inclined or cam-shaped head, is fitted to slide in proper ways (not shown) on the outer face of the upright portion of the carriage C, the lower end of the bar resting on the cam 1, by which it is raised, being allowed to fall by gravitation; or a spring may be employed to depress it and keep it in contact with the cam, if preferred. A knife or cutter, *x*, is also arranged to work vertically on the outer face of the upright portion of the carriage C, being raised by the cam 2, with which its lower end comes into contact, and depressed by the contractile action of the coiled spring *f*, one end of which is secured to the knife and the other to the carriage.

A funnel-shaped rest, *g*, is disposed in the upper section of the carriage C, its axial line and that of the mandrel *z* and the cutter-head D being coincident. Projecting through an aperture in this rest, as shown in Fig. 4, there is a knife or cutter, *d*, affixed to the inner face of the carriage C. There is also a spring-pawl, *i*, pivoted to one edge of the carriage, which intersects with the serrated bar or rack *a*, secured to the bed of the lathe, the pawl being kept in close contact with the rack by means of the weight *n* and strap *o*.

In the use of my invention the blank or stick from which the boxes are to be made is inserted in the machine by placing one end of same in the socket *b* and the other in the rest *g* in the usual manner, power having been previously applied to rotate the driving-pulley G in the direction indicated by the arrow.

The feed-pulley 22 and shaft *y* are then caused to rotate in the same direction, being first coupled together by means of the clutch 14' and lever 13. The arm I being secured to the sleeve 4, and the sleeve caused to rotate with the shaft by means of the spline 12, the inclined side of the cam 21 will be brought into contact with the inclined side of the cam 20, the tendency being to force the sleeves 14 and 16 toward the end of the shaft *y*, opposite the clutch 14'. This being prevented by the ratchet formed by the pawl 18 and serrated spline 12, and the sleeve 16 being also at the same time prevented from revolving with the sleeve 14 by means of the bifurcated arm H, the cam 21, in escaping from the cam 20 as the shaft *y* continues to revolve, will cause the arm I, and with it the carriage C and arm H, to move toward the clutch 14' until the cam 21 passes the cam 20, the ratchet *i a* acting to retain the carriage in its advanced position.

A coiled spring is disposed in an opening

in the lower part of the arm H, one of its ends being attached to the sleeve 16 by the screw 17, and the other to the arm by the screw 19. As the arm advances in the direction of the clutch 14', the sleeve 16 being stationary, this spring is stretched, and when the cam 21 escapes from or passes cam 20, and the sleeves 14 and 16 are thereby freed, the contractile action of the spring will cause the sleeves to slide suddenly along the shaft *y* in the direction of the clutch 14', where they will be retained in their new position by the spline and pawl 12 and 18 until another revolution of the shaft, and the cam 20 is again brought into contact with the cam 21 to repeat the operation.

As the blank or stick passes through the rest *g* it is rapidly rotated by the mandrel *z* and socket *b*, and is "roughed" or reduced to the proper size by the turning knife or cutter *d*. Passing on, (or as the carriage advances,) it is brought into contact with the knife or cutter K, by which the interior of the box is formed, after which the bar *e* is caused to rise by its cam 1, its inclined top striking the collet L at 10, and pushing back or disengaging the cutter-head D and knife K from the blank, the spring *h* yielding to admit of this action. The cutter-head D being removed from the partially-formed box, the cutting-off knife *x* is now caused to advance by means of its cam 2, and cut off the box from the blank or stick, the box dropping into any convenient receptacle, the knife being caused to recede as its cam revolves by means of the spring *f*. In the meantime the feeding mechanism again operates to advance the carriage C, preparatory to forming another box, the bar *e* dropping to permit the spring *h* to force the cutter-head D forward to its normal position and against the blank. When the blank is entirely used up, the pawls *i* and 18 are disengaged and the carriage moved back to the end of the lathe opposite the driving-pulley G, preparatory to inserting a new blank. To prevent the carriage from being fed too far in the direction of the pulley, the clutch lever or shipper 13 is extended above the bed of the lathe in such a manner as to be struck by the carriage as it advances, and thus disconnect the clutch and its pulley.

When the lathe is to be used for the manufacture of spools the cutter-head is fitted with a bit or rimmer, *t*, for boring the hole; or a chuck carrying a bit is used instead of the cutter-head.

A knife or cutter, S, is also mounted in the lever *r*, which is pivoted at Q to the outer face of the carriage C, and works in contact, at its lower end, with the cam 3.

It will be understood that properly-formed knives and tools are to be used in the cutter-head to produce the interior and rabbet or shoulder of the box, and also to turn down and cut off the blank for either boxes or spools, according to the work being done. It will also be understood that the cams 1, 2, 3, and

20 and 21 are to be so constructed and arranged on the shaft, or "timed," as to produce the proper movements and operations of the various parts to which they especially relate.

The object of the spring *h* is to press the cutters against the blank during the operation of turning out the interior of the box with a yielding pressure, to compensate for any inequalities in the texture of the wood, and thus prevent breakage.

Having thus explained my improvement, what I claim is—

1. In a lathe substantially such as described, the shaft *y*, provided with spline 12, sleeves 14, 16, and 4, in combination with the cams 20 and 21, pawl 18, and carriage C, provided with arms H I, the former having a coiled spring disposed in an opening in its lower part, all constructed and arranged to operate substantially as set forth.

2. In a lathe substantially such as described, the cam 1, vertically-reciprocating bar *e*, having an inclined or cam-shaped head, collet L, having arm 10, and the cutter-head D, combined to operate substantially as and for the purpose set forth and specified.

3. The shaft *y*, provided with spline 12, sleeves 4, 14, and 16, in combination with the cams 20 21, pawl 18, pawl *i*, rack *a*, and carriage C, provided with arms H I, the former having a coiled spring disposed in an opening in its lower part, substantially as and for the purpose set forth.

JAMES MAY.

Witnesses:

C. A. SHAW,
H. E. METCALF.